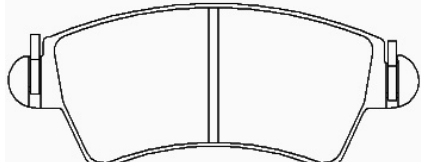
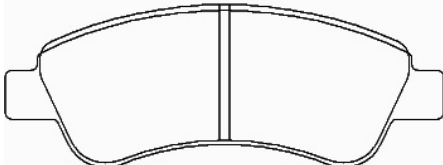
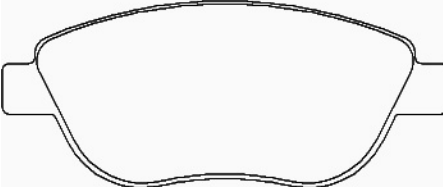

Peugeot 206GTi and 206GTi180 Discs and Pads.

There are 2 options for 206GTi's, sometime in 2002 when the 206GTi gained 16" rims and became full multiplex, the brake pads, discs and callipers were updated. All 206GTi's and GTi180 have the same rear disc/pad setup.

206GTi 99-01 / Front Disc	206GTi 99-01 / Front Pad
Hight total 27.4mm Diameter 266mm Diameter interior 66mm Maximum thickness 20.5mm Minimum thickness 18.6mm	Height 52.6mm Width 130.8mm Thickness 18mm 

206GTi 02-onwards / Front Disc	206GTi 02-onwards / Front Pad
Hight total 34mm Diameter 266mm Diameter interior 66mm Maximum thickness 22mm Minimum thickness 20mm	Height 50.1mm Width 136.8mm Thickness 19mm 

206GTi180 / Front Disc	206GTi180 / Front Pad
Hight total 34mm Diameter 283mm Diameter interior 66mm Maximum thickness 26mm Minimum thickness 24mm	Height 57.4mm Width 136.8mm Thickness 19mm 

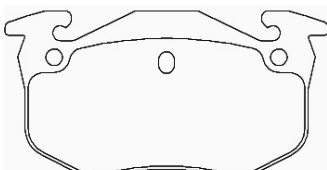
206GTi and GTi180 / Rear Disc	206GTi180 / Rear Pad
Hight total 25.3mm Diameter 247mm Diameter interior 71mm Maximum thickness 8mm Minimum thickness 6mm	Height 55mm Width 105.1mm Thickness 11mm 

*NOTE: ALL instructions/measurements are there as a guide only, any decisions or actions you undertake are at your own risk – 206gti.net nor the author of this document do not take any responsibility for matters arising from the use of this document. We recommend that you seek professional assistance in performing any motor vehicle maintenance. Diagrams are not to scale.*